

INSTALLATION INSTRUCTIONS

P5 Universal Pressure Sensor 0-5/10/25" W.C. Models With Four Selectable Ranges



Versatile probe: remote or duct mount

- RP-6 Remote/duct probe, 6"
- Accepts both 1/8" and 1/4" tubing

PRODUCT APPLICATION LIMITATION:

Senva products are not designed to be used as the lone device for life or safety applications. Senva products are not intended for use in critical applications such as nuclear facilities, human implantable device or life support. Senva believes a systems approach to safety is necessary for these types of applications. Senva is not liable, in whole or in part, for any claims or damages arising from such uses.

INSTALLATION

1. Screw mount sensor directly to duct, or in panel using self-tapping screws or attach to a DIN rail (2 possible orientations for DIN mounting, BACK and LEFT SIDE).
2. Move slide switch to select appropriate analog output (4-20mA 2-Wire or 3-Wire configurations or 5V/10V)
3. Move slide switch to select desired pressure range and operation mode (Uni or Bi-Directional)
4. Plumb air lines to sensor hose barbs (Accepts 1/8" & 1/4" ID tubing). High (+) and low (-) ports are labeled on the sensor.
5. Wire sensor for voltage or current output as shown in the wiring diagrams.
6. Recommendation: Apply power to sensor. With no pressure applied, press the ZERO SET button for 2-seconds. (For best results, temporarily connect high and low pressure ports

LED STATUS/INDICATION

LED indicator will flash every 5 seconds for normal operation.

LED indicator will rapidly flash when applied pressure greater than 110% of selected range.

LED indicator will rapidly flash momentarily when zeroing process is complete.

WIRING DIAGRAMS

3 - Wire 4 - 20mA

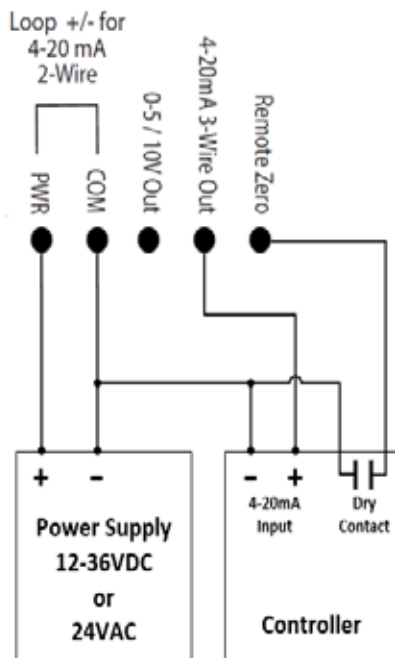

2 - Wire 4 - 20mA

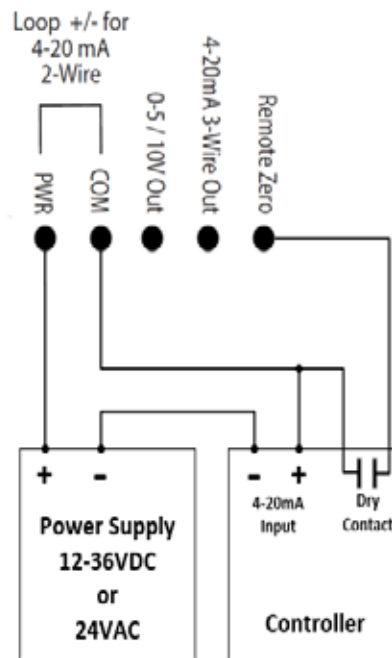

Selectable 0-5V and 0-10V

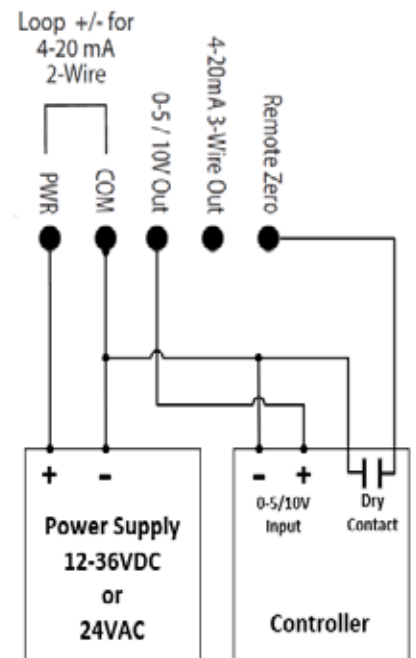

SPECIFICATIONS

Power supply	12-30VDC/24VAC ⁽¹⁾ , 30mA max.	
Outputs	3-wire 0-5V/10V, 4-20mA loop powered, 3-wire 4-20mA	
Output scaling	Max Range (Selectable Ranges)	0-5" (0.1/0.25/2.5/5" wc), 0-1250Pa(25/50/625/1250Pa) 0-10" (1.0/2.5/5/10" wc), 0-2500Pa(250/625/1250/2500Pa) 0-25" (5/10/15/25" wc), 0-6250Pa(1250/2500/3750/6250Pa)
Operating Temperature	Operating Range Compensated Range	-4°F to 185°F (-20°C to 85°C) 32°F to 122°F (0°C to 50°C)
Media Compatibility	Dry, oil-free air. Nitrogen.	
Sensor Type	Precision calibrated	MEMS silicon piezoresistive
Accuracy	Combined linearity and hysteresis	+/- 1.0% of selected range
Enclosure	Auto-zero input	Pushbutton and contact closure input
	Material	ABS
	Dimensions	4.75"h x 1.82"w x 0.90"d

(1) One side of transformer secondary is connected to signal common. Dedicated transformer is recommended.

TYPICAL APPLICATIONS

Velocity: Use a pitot tube and plumb high (+) port to total pressure (Pt) connection and low (-) port to static pressure (Ps) connection to directly read $P_t - P_s = P_v$. Apply correction constant provided by pitot tube manufacturer.

Duct Static: Install a static pressure pickup tube approximately 2/3 of the way down the discharge air duct and plumb to high (+) port for positively pressurized ducts.

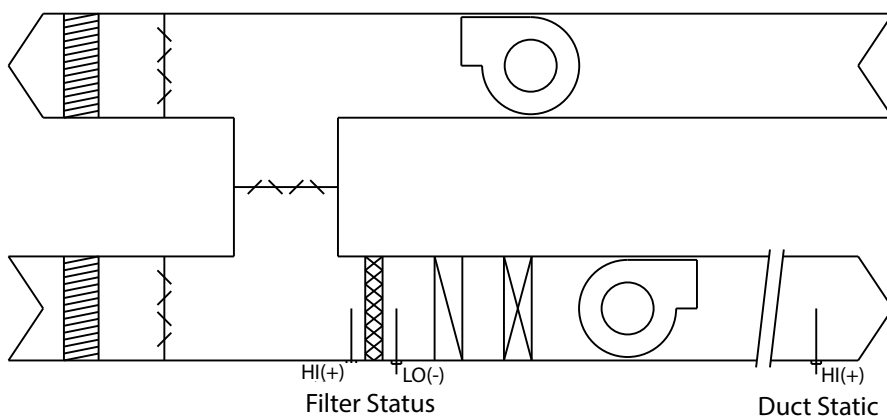

DIMENSIONS

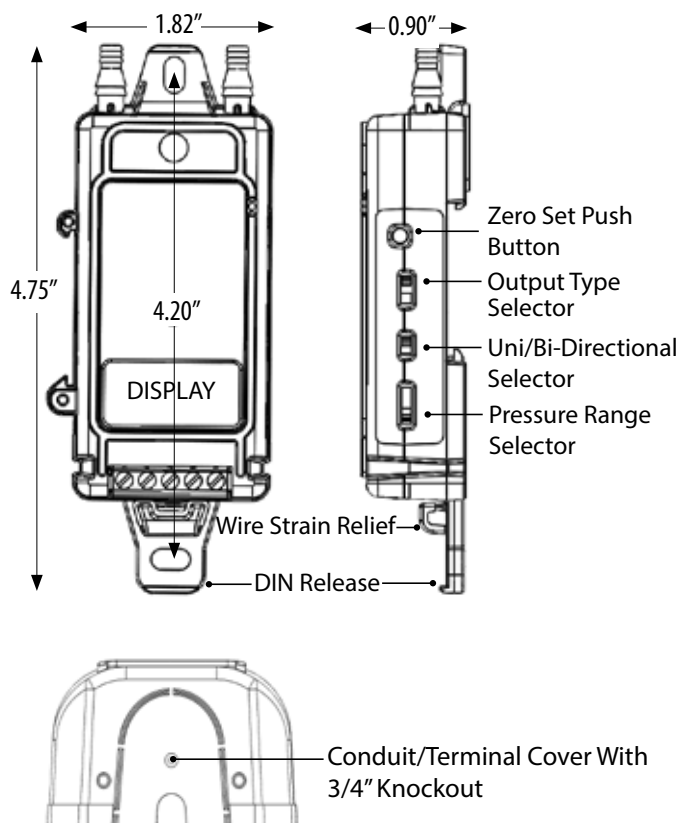

IMPORTANT!

IMPORTANT WARNINGS

- Only qualified trade installers should install this product
- This product is not intended for life-safety applications
- Do not install in hazardous or classified locations
- The installer is responsible for all applicable codes
- De-energize power supply prior to installation or service
- Forming a "drip-loop" (allowing tubing to dip below the level of the sensor hose barbs) is recommended to protect the sensor from damage caused by condensation.

TROUBLESHOOTING

Symptom	Solution
No output	Check wiring. Ensure power supply meets requirements.
Pressure reading error	Verify control panel software is configured for correct output scaling.
	Verify switch settings.
	Verify tubing is not pinched or leaking.
	Possible contamination. Ensure sensor is used only on dry air or nitrogen.